



# HD IR Dual Lens Dome Network Camera

Quick Start Guide

## Table Of Contents

### Features and Specifications

- A. Overview 2
- B. Camera Interface 2

### Camera Installation

- A. Installation Steps 3-4
- B. Restore Factory Defaults and Installing SD card 5

### Quick Configuration Tool

- A. Overview 5
- B. Operation 5-6

### Web Operation

- A. Network Connection 7
- B. Login and Logout 7-8

### Appendices

- C. FAQ 9
- D. Toxic or Hazardous Elements 9-10

## IMPORTANT SAFEGUARDS AND WARNINGS

### Electrical Safety

All installation and operation here should conform to your local electrical safety codes. The power shall conform to the requirement in the SELV (Safety Extra Low Voltage) and the Limited power source is rated 12V DC in the IEC60950-1. This series product supports PoE too. Please note: Do not connect these two power supplying sources to the device at the same time; it may result in device damage! We assume no liability or responsibility for all the fires or electrical shock caused by improper handling or installation. We are not liable for any problems caused by unauthorized modification or attempted repair.

### Transportation Security

Care must be given to avoid heavy stress, violent vibration or water damage during transportation, storage and installation.

### Installation

Do not apply power to the camera before completing installation. Please install the proper power cut-off device during the installation connection. Always follow the instruction guide the manufacturer recommended.

### Qualified engineers needed

All the examination and repair work should be done by the qualified service engineers. We are not liable for any problems caused by unauthorized modifications or attempted repair.

### Environment

This series network camera should be installed in a cool, dry place away from direct sunlight, inflammable, explosive substances and etc. Please keep it away from the electromagnetic radiation object and environment. Please make sure the CCD (CMOS) component is out of the radiation of the laser beam device. Otherwise it may result in CCD (CMOS) optical component damage. Please keep the sound ventilation. Do not allow the water and other liquid falling into the camera. Lightning-proof device is recommended to be adopted to better prevent lightning damage. The grounding studs of the product are recommended to be grounded to further enhance the reliability of the camera.

### Daily Maintenance

Please shut down the device and then unplug the power cable before you begin daily maintenance work. Do not touch the CCD (CMOS) optic component. You can use the blower to clean the dust on the lens surface. Always use the dry soft cloth to clean the device. If there is too much dust, please use the water to dilute the mild detergent first and then use it to clean the device. Finally use the dry cloth to clean the device. Please put the dustproof cap to protect the CCD (CMOS) component when you do not use the camera.

### Accessories

Be sure to use all the accessories recommended by manufacturer. Before installation, please open the package and check all the components are included. Contact your local retailer ASAP if something is broken in your package.

## 1A. OVERVIEW

This series network camera integrates the traditional camera and network video technology. It adopts video data collection and transmission together. It can connect to the network directly without any auxiliary device.

This series network camera uses standard H.264 and H.265 video compression technology, which maximizes the video storage and quality. This camera includes a built-in microphone. It powers with either 12V DC or POE.

The camera supports the IR night vision function. In the night environments, the device can use the IR light to highlight the object which is suitable for the surveillance function in the low illumination environments. The waterproof design conforms to the IP67 level. It has the sound waterproof function suitable for use in the outdoor environments.

It can be used standalone or with a network video recorder. If used standalone, it is able to utilize IC Realtime's software suite including Smart ICRSS, IC View and ICRSS Pro. This model also supports IC Realtime's P2P connection which allows easy remote connection.

## 1B. Camera Interface

See Figure 1-1

1. I/O: Includes Audio and Alarm Input/ Outputs.
2. LAN: Ethernet port to connect with network cable. Supports PoE+
3. Reset Button.
4. SD Card Slot.
5. POWER: For 24VAC power connection.

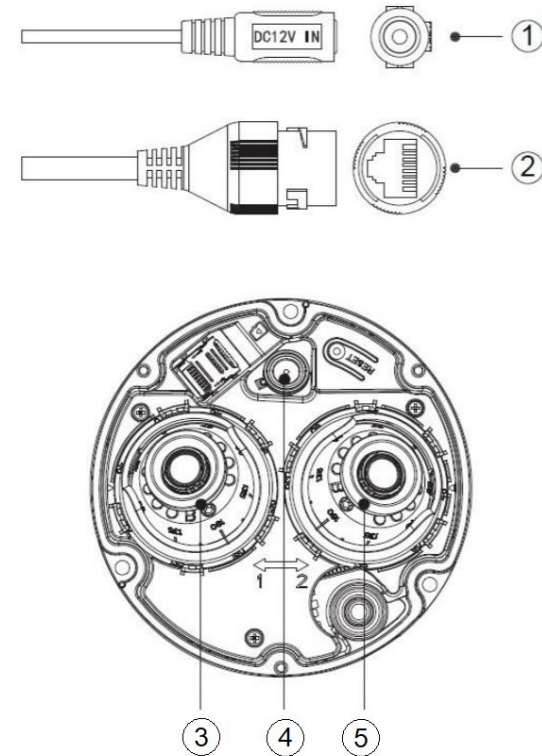

Figure 1-1

## 2A. INSTALLATION STEPS

- Note: Please make sure the installation surface can support at least 3X weight of the camera and the bracket.

**Step 1** use the supplied wrench to remove the the fixing screws from the dome enclosure and remote it from the pedestal. See Figure 2-1.

**Step 2** Take out installation position map and stick it on the mounting surface according to the location cable exit, and then drill holes on the mounting surface, following the instructions on the installation position map.

**Step 3** Take out the expansion bolts and insert them into the mounting holes.

**Step 4** Adjust the location of device pedestal according to the requirement of wiring.

- If installing the cable from the rear, make sure a cable exit hole is drilled in accordance to the position map. Thread the camera pigtail through the cable exit hole before securing the pedestal with the self tapping screws.
- If the side exit is used, you will need to remove the cable cutout tab on the pedestal. The pigtail will route through this.

**Step 5** Align the screw mounting holes on the pedestal with those of expansion bolts on the mounting surface, and then tighten the self-tapping screws into the expansion bolts and tighten them firmly.

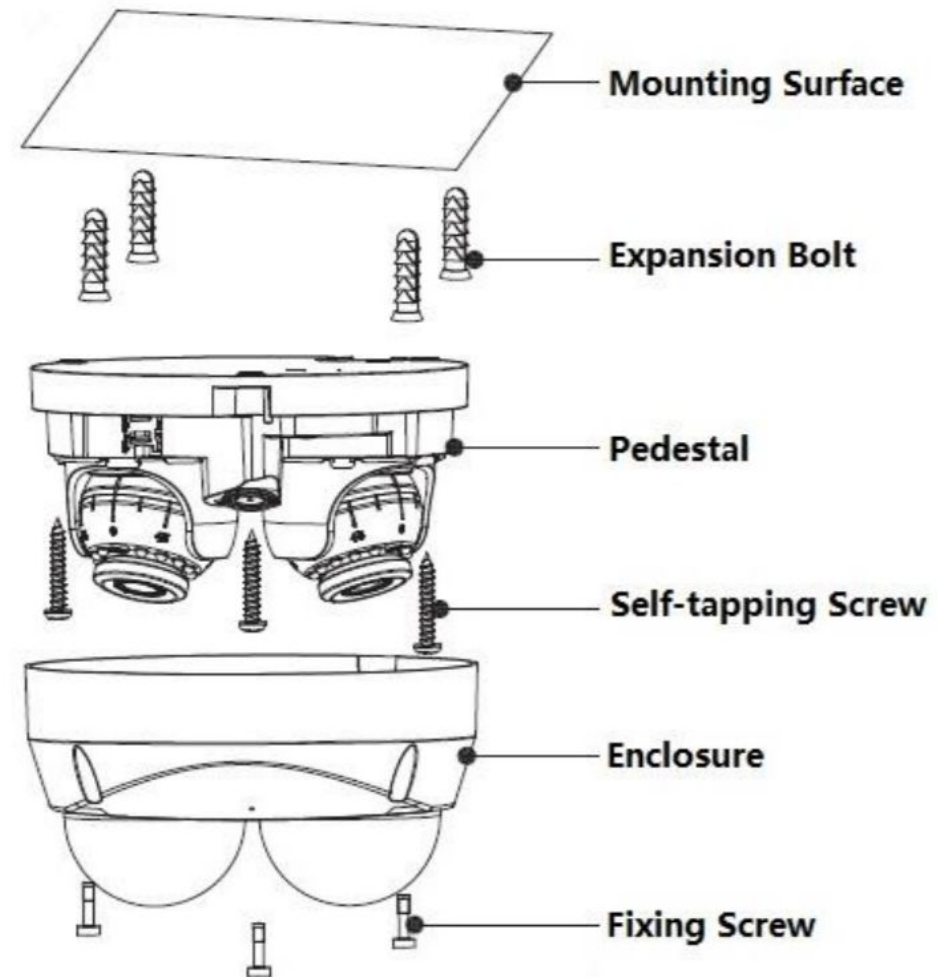

Figure 2-1

**Step 6:** Adjusting Lens angle: See Figure 2-2 to adjust lens angle.

- Lens horizontal rotation: Manually rotate the lens and adjust the horizontal rotation direction of monitoring.
- Lens vertical rotation and image horizontal rotation: Use wrench and insert it into the adjustment hole on the lens surface, rotate the wrench to adjust lens.

Reinstall the enclosure to the pedestal when finished.

The range of lens adjusting angle: horizontal ( $-90^{\circ} \sim 90^{\circ}$ ), vertical ( $0^{\circ} \sim +65^{\circ}$ ), image rotation direction ( $0^{\circ} \sim +360^{\circ}$ ).

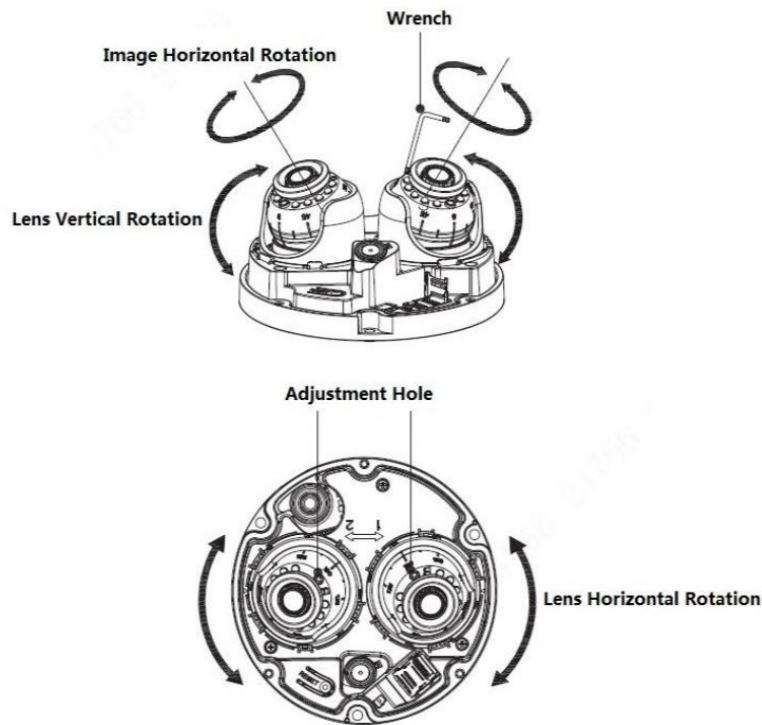

Figure 2-2

**Waterproof connector installation for network port (if applicable):** For a device with a plastic enclosure, you can directly rotate the dome enclosure clockwise, cover the dome enclosure and complete installation. See figure 2-7.

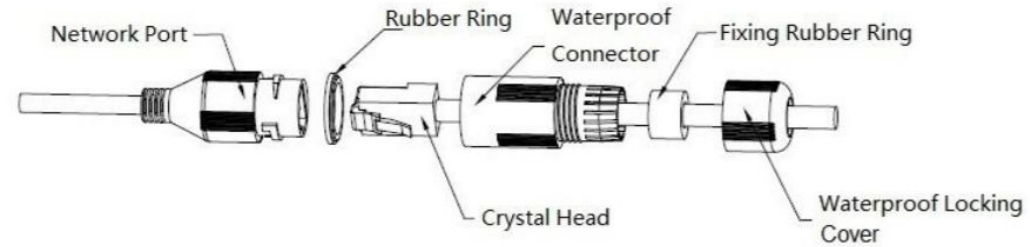

Figure 2-3

**Step 1:** Keep the convex groove outward and install the rubber ring into the network port, keep the smaller hole of the rubber ring outward and install the fixing rubber ring into the main body of the waterproof connector.

**Step 2:** Pull the network cable without crystal head through main body of waterproof connector, fixing rubber ring and waterproof locking cover, make the crystal head of network cable, and then insert it into the network cable

**Step 3:** Put the main body of waterproof connector on the network port and rotate it clockwise to lock the network port and waterproof connector firmly

**Step 4:** Put the waterproof locking cover on the main body of waterproof connector and rotate it clockwise to lock the waterproof connector and waterproof locking cover firmly. It is recommended to wrap the assembly with electrical tape for an extra protective measure.

## 2B. RESTORE FACTORY DEFAULTS/ INSTALL SD CARD

**Important:** Make sure the device is powered when attempting to press RESET button.

**Step 1** Use the supplied hex wrench to remove camera cover. Skip to Step 3 if only installing SD card.

**Step 2** Press the RESET button for 15-30 seconds to complete the reset function. See Figure 2-4. The camera will reboot when the reset process is complete.

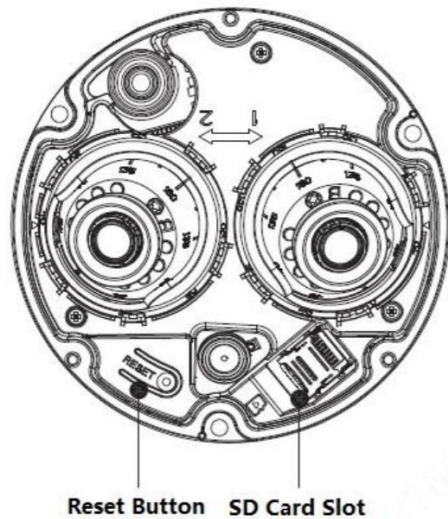

Figure 2-4

**Step 3 (If installing SD Card)** Adjust the Micro SD Card to a proper direction shown in Figure 2-7. Max supported is 128GB micro SD,

**Step 5** Tighten down locking screw and reinstall camera.

## 3A. OVERVIEW

The IP Config tool is used to search the local network for IC Realtime devices as well as modify the IP addresses and upgrading firmware.

This software can be downloaded at:

<https://icrealtime.com/downloads> under Desktop Utility Apps

## 3B. OPERATION

Double click the “ConfigTools.exe” icon to run. The interface will be displayed as shown in Figure 3-1. Click on the blue circle icon with the two arrows to refresh and scan the network.

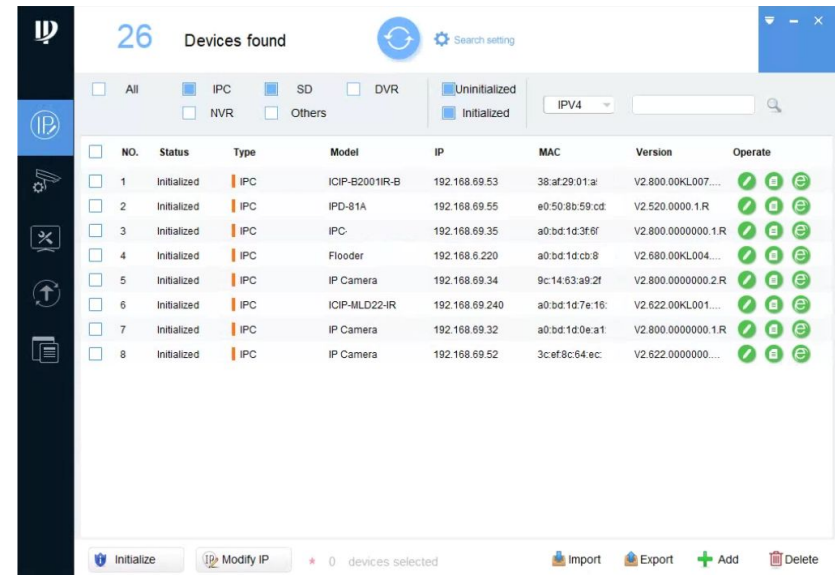

Figure 3-1

Select “Search Setting” to modify the IP range to scan for and input the correct login information for the device. See Figure 3-2.

Setting

Current Segment Search     Other Segment Search

Start IP: 192 . 168 . 69 . 1    End IP: 192 . 168 . 69 . 255

Username: admin    Password: .....

OK

Figure 3-2

**Note:** If the Camera status is “Uninitialized,” select the camera and then click the “Initialize” icon on the bottom left side and follow the process on screen to initialize the device.

The Operate column will allow you to modify device, view device information and link to web browser. See figure 3-3.



Figure 3-3

To modify the device IP address, select one of the devices from the list and then click the pencil icon. The dialog box to modify the IP information will populate. See Figure 3-4.

Modify IP Address

Mode:  Static     DHCP

Target IP: [ . . . ]

Subnet Mask: [ . . . ]

Gateway: [ . . . ]

Selected number of devices: 1    OK

Figure 3-4

This series network camera product supports the Web access and management via PC.

#### 4A. NETWORK CONNECTION

Please follow the steps listed below for network connection.

- Make sure the network camera is connected to the network and powered properly.
- Please set the IP address, subnet mask and gateway of the PC and the network camera respectively. The camera is set to DHCP out of the box with default IP address of 192.168.1.108 if DHCP pool is not available. Subnet mask is 255.255.255.0. Gateway is 192.168.1.1
- Using Command Prompt, type “ping \*\*\*.\*\*\*.\*\*\*.\*\*\*(\* network camera address)” to check if connection is OK or not.

#### 4B. LOGIN AND LOGOUT

Open IE or Chrome and input the network camera address in the address bar. See Figure 4-1.

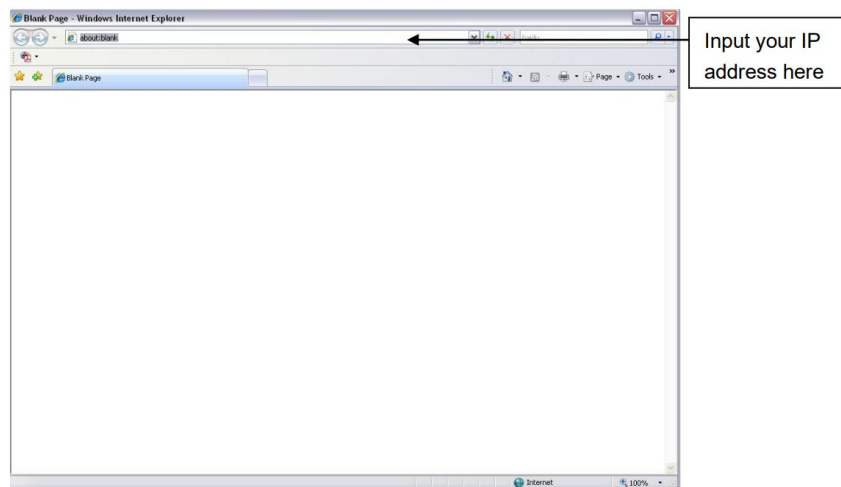

Figure 4-1

The login interface is shown as below. See Figure 4-2.

**Note:** If it is your first time logging into the camera (and it has not been initialized through the ConfigTool or NVR), the camera will need to be initialized. A pop-up will appear to select your region. After selecting region, you will be prompted to create a password for the admin account as well as security questions in case the password is lost After initializing, you will be able to login to the web interface of the camera.

Please input your user name and password.



Figure 4-2

Web includes several modules: monitor channel preview, system configuration, alarm and etc. See Figure 4-3.

- Live: Live video of camera
- Playback: View recording from SD card (if applicable)
- Setting: For configuration changes.
- Alarm: For monitoring alarm triggers (motion detect, IVS, abnormalities, etc)
- Logout: Logs out of the camera web GUI

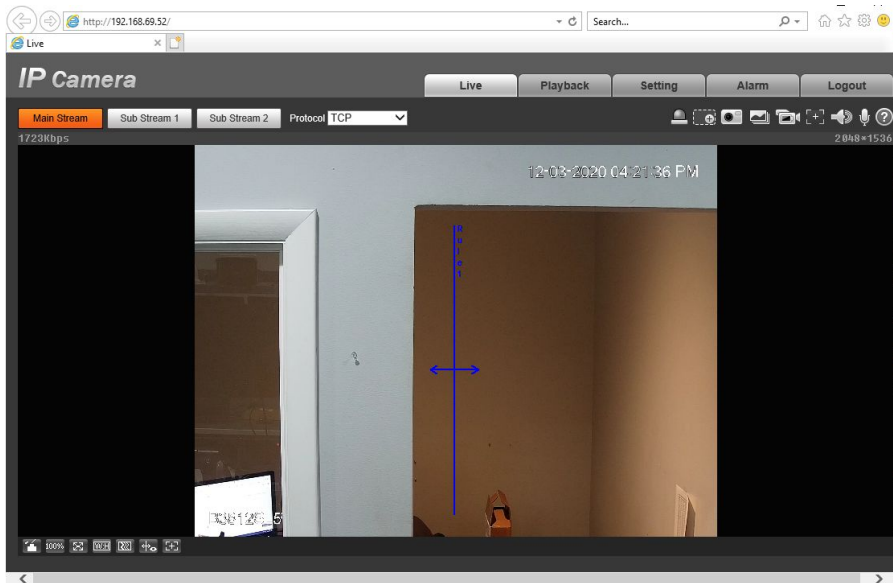









Figure 4-3

#### Live View Functions:

	<p>Relay Out: Displays alarm output state. Click the icon to enable or disable alarm output.</p> <ul style="list-style-type: none"> <li>• Red: Alarm output enabled.</li> <li>• Grey: Alarm output disabled.</li> </ul>
	<p>Digital Zoom: Click the icon, and then select an area in the video image to zoom in; right-click on the image to resume the original size. In zoom in state, drag the image to check other area. Scroll the mouse wheel in the video image to zoom in or out.</p>
	<p>Snapshot: Click the icon to capture one picture of the current live view. It will be saved to the configured storage path.</p>
	<p>Triple Snapshot: Click the icon to capture three pictures of the current live view. They will be saved to the configured storage path.</p>
	<p>Record: Click the icon to record live video. It will be saved to the configured storage path.</p>
	<p>Easy Focus: Click the icon to display the AF Peak (focus eigenvalue) and AF Max (max focus eigenvalue) on the video image.</p>
	<p>Audio: Click the icon to enable or disable audio output.</p>
	<p>Talk: Click the icon to enable or disable the 2 way talk.</p>

## 5A. FAQ

<b>Device does not operate properly/ lost password.</b>	Please refer to section 2B for factory reset process. Cam will need to be Initialized after factory reset.
<b>The water leakage.</b>	The front or rear cap if damaged or removed can result in water leakage. The glass dome may also have been compromised from heavy strikes or heavy pressure. The waterproof plug of the rear cap may also have loosened.
<b>IR video is poor/ does not turn on.</b>	Verify the camera is supplied with the recommended amount of power. You may need to test voltage/ amperage of the camera while under load. Enough visible light at the location can also cause IRs to not switch on.
<b>I can not upgrade the device via network.</b>	Contact technical support to request firmware.
<b>I cannot login to the client-end or the WEB.</b>	If the Camera HTTP port is changed, you will need to specify the port number after the IP. (ex: <a href="http://192.168.1.108:8080">http://192.168.1.108:8080</a> ) Ensure the correct login credentials are being used. The Smart ICRSS software will use the TCP port. Make sure you input the correct TCP port number.
<b>The account is locked</b>	Reboot the camera to clear lock out. Verify the login to make sure it is correct.

<b>P2P status is “not connected/ offline”</b>	You may need to set device IP to DHCP. After acquiring a different IP address, verify P2P status and set camera back to static IP if successful.
<b>Camera does not show up on local network.</b>	Verify the camera is supplied with the recommended power supply. Change network cable or use short patch cable to troubleshoot.

## 5B. APPENDIX TOXIC OR HAZARDOUS MATERIALS OR ELEMENTS

Component Name	Pb	Hg	Cd	Cr VI	PBB	PBDE
<b>Circuit Board Component</b>	●	●	●	●	●	●
<b>Device Case</b>	●	●	●	●	●	●
<b>Wire and Cable</b>	●	●	●	●	●	●
<b>Packing Components</b>	●	●	●	●	●	●
<b>Accessories</b>	●	●	●	●	●	●

O: Indicates that the concentration of the hazardous substance in all homogeneous materials in the parts is below the relevant threshold of the SJ/T11363-2006 standard.

X: Indicates that the concentration of the hazardous substance of at least one of all homogeneous materials in the parts is above the relevant threshold of the SJ/T11363-2006 standard. During the environmental-friendly use period (EFUP) period, the toxic or hazardous substance or elements contained in products will not leak or mutate so that the use of these (substances or elements) will not result in any severe environmental pollution, any bodily injury or damage to any assets. The consumer is not authorized to process such kind of substances or elements, please return to the corresponding local authorities to process according to your local government statutes.

**Note:**

- This user's manual is for reference only. Slight difference may be found in user interface.
- All the designs and software here are subject to change without prior written notice.
- All trademarks and registered trademarks mentioned are the properties of their respective owners.
- If there is any uncertainty or controversy, please refer to the final explanation of us.
- Please visit our website for more information.